

CB59 CB62



- Feedback encoder series for servo and gearless motors
- 2,048 PPR sine/cosine output + CD track for rotor position
- CB59: Ø 12.7-mm (1/2") and 15-mm (0.59") hollow shaft
- CB62: Ø 10-mm (0.39") 1:10 tapered solid shaft
- Many mounting options (expansion flange and fixing plates)

Suitable for the following models:

- CB59
- CB62

General Contents

1 - Safety summary	6
2 - Identification	7
3 - Mounting instructions	8
4 - Electrical connections	15
5 - Output signals	18

This publication was produced by Lika Electronic s.r.l. 2020. All rights reserved. Tutti i diritti riservati. Alle Rechte vorbehalten. Todos los derechos reservados. Tous droits réservés.

This document and information contained herein are the property of Lika Electronic s.r.l. and shall not be reproduced in whole or in part without prior written approval of Lika Electronic s.r.l. Translation, reproduction and total or partial modification (photostat copies, film and microfilm included and any other means) are forbidden without written authorisation of Lika Electronic s.r.l.

The information herein is subject to change without notice and should not be construed as a commitment by Lika Electronic s.r.l. Lika Electronic s.r.l. reserves the right to make all modifications at any moments and without forewarning.

This manual is periodically reviewed and revised. As required we suggest checking if a new or updated edition of this document is available at Lika Electronic s.r.l.'s website. Lika Electronic s.r.l. assumes no responsibility for any errors or omissions in this document. Critical evaluation of this manual by the user is welcomed. Your comments assist us in preparation of future documentation, in order to make it as clear and complete as possible. Please send an e-mail to the following address info@lika.it for submitting your comments, suggestions and criticisms.

The logo for Lika Electronic s.r.l. consists of the word "lika" in a bold, lowercase, sans-serif font. The letter "i" has a dot above it. The logo is positioned in the bottom right corner of the page.

General contents



User's guide.....	1
General contents.....	3
Typographic and iconographic conventions.....	4
Preliminary information.....	5
1 - Safety summary.....	6
1.1 Safety.....	6
1.2 Electrical safety.....	6
1.3 Mechanical safety.....	6
2 - Identification.....	7
3 - Mounting instructions.....	8
3.1 CB59 encumbrance sizes.....	8
3.1.1 Installing the CB59 encoder.....	8
3.1.2 Dismounting the CB59 encoder.....	9
3.2 CB62 encumbrance sizes (standard version).....	10
3.2.1 Installing the CB62 encoder (standard version).....	10
3.2.2 Dismounting the CB62 encoder (standard version).....	11
3.3 CB62 encumbrance sizes (A order code).....	12
3.4 CB62 encumbrance sizes (B order code).....	12
3.5 CB62 encumbrance sizes (D order code).....	13
3.6 CB62 encumbrance sizes (E order code).....	13
3.6.1 Mounting the CB62 encoder (A, B, D and E order codes).....	13
3.6.2 Dismounting the CB62 encoder (A, B, D and E order codes).....	14
4 - Electrical connections.....	15
4.1 98414-G05-14-LF 14-pin connector.....	16
4.2 EC-ASB/CB62-xx connection cable.....	16
4.3 TF12 connection cable specifications.....	16
4.4 Cable shield connection to ground.....	17
5 - Output signals.....	18
5.1 Output signals level.....	19

Typographic and iconographic conventions

In this guide, to make it easier to understand and read the text the following typographic and iconographic conventions are used:

- parameters and objects both of the device and the interface are coloured in **GREEN**;
- alarms are coloured in **RED**;
- states are coloured in **FUCSIA**.

When scrolling through the text some icons can be found on the side of the page: they are expressly designed to highlight the parts of the text which are of great interest and significance for the user. Sometimes they are used to warn against dangers or potential sources of danger arising from the use of the device. You are advised to follow strictly the instructions given in this guide in order to guarantee the safety of the user and ensure the performance of the device. In this guide the following symbols are used:

	This icon, followed by the word WARNING, is meant to highlight the parts of the text where information of great significance for the user can be found: user must pay the greatest attention to them! Instructions must be followed strictly in order to guarantee the safety of the user and a correct use of the device. Failure to heed a warning or comply with instructions could lead to personal injury and/or damage to the unit or other equipment.
	This icon, followed by the word NOTE, is meant to highlight the parts of the text where important notes needful for a correct and reliable use of the device can be found. User must pay attention to them! Failure to comply with instructions could cause the equipment to be set wrongly: hence a faulty and improper working of the device could be the consequence.
	This icon is meant to highlight the parts of the text where suggestions useful for making it easier to set the device and optimize performance and reliability can be found. Sometimes this symbol is followed by the word EXAMPLE when instructions for setting parameters are accompanied by examples to clarify the explanation.

Preliminary information

This guide is designed to provide the most complete information the operator needs to correctly and safely install and operate **CB59 and CB62 encoders**. It further describes the **EC-ASB/CB62-xx connection cable**.

CB59 and CB62 encoders are engineered to deliver feedback signals to know both position and speed of servo motors and gearless motors. In addition to sine/cosine 1Vpp signals, an absolute signal (CD absolute track) is generated to provide information about the position of the motor poles needful at motor start-up.

For technical specifications please [refer to the product datasheet](#).

1 - Safety summary



1.1 Safety

- Always adhere to the professional safety and accident prevention regulations applicable to your country during device installation and operation;
- installation and maintenance operations have to be carried out by qualified personnel only, with power supply disconnected and stationary mechanical parts;
- device must be used only for the purpose appropriate to its design: use for purposes other than those for which it has been designed could result in serious personal and/or the environment damage;
- high current, voltage and moving mechanical parts can cause serious or fatal injury;
- warning ! Do not use in explosive or flammable areas;
- failure to comply with these precautions or with specific warnings elsewhere in this manual violates safety standards of design, manufacture, and intended use of the equipment;
- Lika Electronic assumes no liability for the customer's failure to comply with these requirements.



1.2 Electrical safety

- Turn OFF the power supply before connecting the device;
- connect according to the explanation in the "4 - Electrical connections" section on page 15;
- wires of output signals which are not used must be insulated singularly;
- in compliance with 2014/30/EU norm on electromagnetic compatibility, following precautions must be taken:
 - before handling and installing the equipment, discharge electrical charge from your body and tools which may come in touch with the device;
 - power supply must be stabilized without noise; install EMC filters on device power supply if needed;
 - we suggest using the connection cable code **EC-ASB/CB62-xx** (on request);
 - avoid cables runs longer than necessary;
 - avoid running the signal cable near high voltage power cables;
 - mount the device as far as possible from any capacitive or inductive noise source; shield the device from noise source if needed;
 - minimize noise by connecting to ground (GND) the cable shield or the device housing. Make sure that ground (GND) is not affected by noise. The shield connection point to ground can be situated both on the device side and on user's side. The best solution to minimize interference must be carried out by the user.



1.3 Mechanical safety

- Install the device following strictly the information in the "3 - Mounting instructions" section on page 8;
- mechanical installation has to be carried out with stationary mechanical parts;
- do not disassemble the device;
- do not tool the device;

- delicate equipment: handle with care; do not subject the device to knocks or shocks;
- respect the environmental characteristics declared by the manufacturer.

2 - Identification

Device can be identified through the **order code** and the **serial number** printed on the label applied to its body. Information is listed in the delivery document too. Please always quote the order code and the serial number when reaching Lika Electronic. For any information on the technical characteristics of the product **refer to the technical catalogue**.



Warning: encoders having order code ending with "/Sxxx" may have mechanical and electrical characteristics different from standard and be supplied with additional documentation for special connections (Technical Info).

3 - Mounting instructions



WARNING

Installation and maintenance operations must be carried out by qualified personnel only, with power supply disconnected and mechanical parts absolutely in stop. Do not tool the unit.

3.1 CB59 encumbrance sizes

(values are expressed in mm)

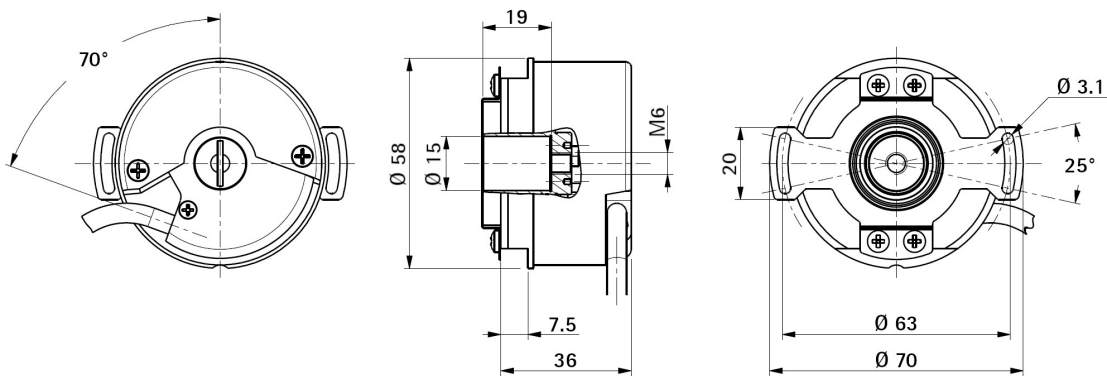

Figure 1 - CB59 encumbrance sizes

3.1.1 Installing the CB59 encoder

For correct installation the motor shaft must be fitted with an M5-threaded bore (see Figures below).

To install the encoder please follow carefully the next steps:

- remove the PG cap **1** from the back of the encoder;
- fit the encoder into the rotor shaft **2** and fix it using the provided M5 x 10 UNI 5931 screw **3**; the recommended tightening torque is **5 Nm**;

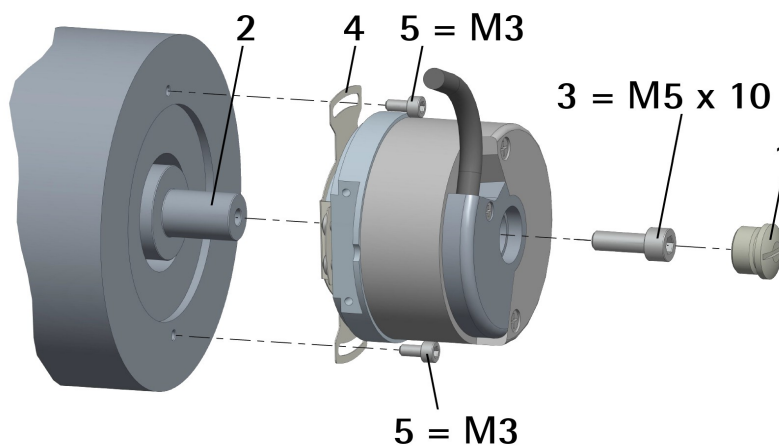

Figure 2 - Mounting of CB59 encoder

- replace the PG cap 1 properly and tighten it;
- fasten the fixing plate 4 to the motor frame using two M3 screws 5.

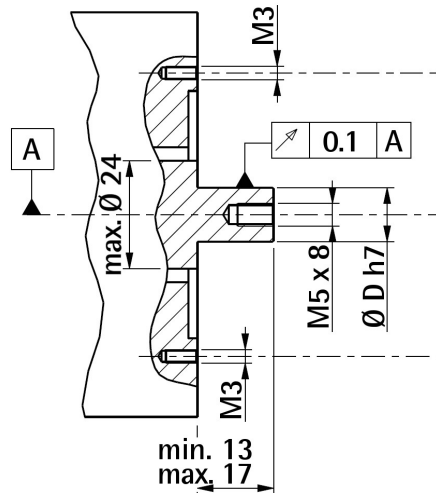

Figure 3 - CB59 installation tolerances

3.1.2 Dismounting the CB59 encoder

To dismount the encoder please follow carefully the steps described hereinafter:

- unscrew the fixing plate 4 from the motor frame;
- remove the PG cap 1 from the back of the encoder;
- hold the rotor shaft 2 and screw off the M5 screw 3 which fixes the encoder shaft to the rotor shaft 2.



WARNING: do not force the encoder manually to pull it out!

- ensure that the rotor shaft 2 does not move and carefully tighten an M6 screw instead of the M5 screw in the encoder shaft: tightening the M6 screw will cause the encoder shaft to be drawn out slowly. To prevent the thread of the rotor shaft 2 from being damaged we suggest tightening an M5 grub screw before screwing in the M6 screw.

3.2 CB62 encumbrance sizes (standard version)

(values are expressed in mm)

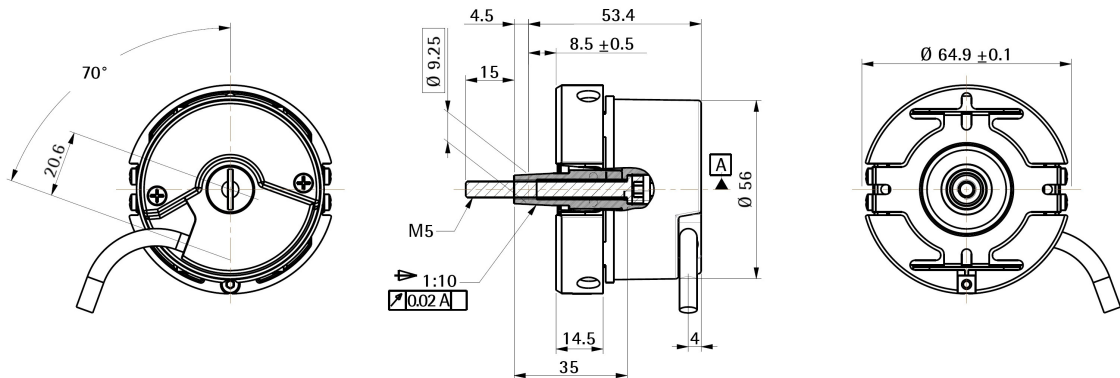

Figure 4 - CB62 encumbrance sizes (standard version)

3.2.1 Installing the CB62 encoder (standard version)

For correct installation the motor shaft must be fitted with an M5-threaded bore (see Figures below).

To install the encoder please follow carefully the next steps:

- remove the PG cap **1** from the back of the encoder;
- fit the encoder into the rotor shaft **2** and fix it using the provided M5 x 50 UNI 5931 screw **3**; the recommended tightening torque is **5 Nm**;
- replace the PG cap **1** properly and tighten it;
- tighten the M3 screw **4** to cause the flange **5** to expand so clamping the encoder onto the stator **6**; the recommended tightening torque is **1.2 Nm**.

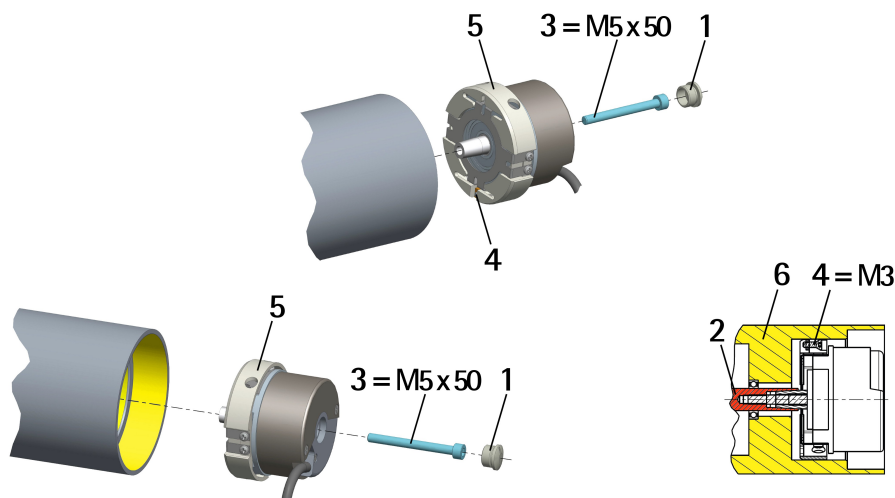

Figure 5 - Mounting of CB62 encoder (standard version)

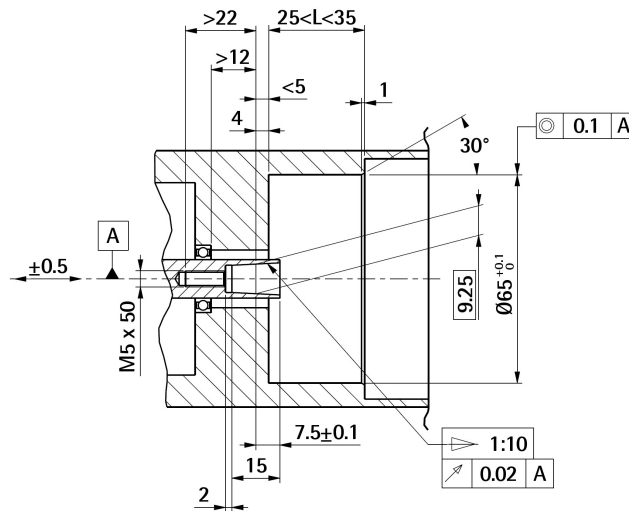

Figure 6 - CB62 installation tolerances (standard version)

3.2.2 Dismounting the CB62 encoder (standard version)

To dismount the encoder please follow carefully the steps described hereinafter:

- unscrew the M3 screw 4 to release the expansion flange 5;
- remove the PG cap 1 from the back of the encoder;
- hold the rotor shaft 2 and screw off the M5 screw 3 which fixes the encoder shaft to the rotor shaft 2.



WARNING: do not force the encoder manually to pull it out!

- ensure that the rotor shaft 2 does not move and carefully tighten an M6 screw instead of the M5 screw in the encoder shaft: tightening the M6 screw will cause the encoder shaft to be drawn out slowly. To prevent the thread of the rotor shaft 2 from being damaged we suggest tightening an M5 grub screw before screwing in the M6 screw.

3.3 CB62 encumbrance sizes (A order code)

(values are expressed in mm)

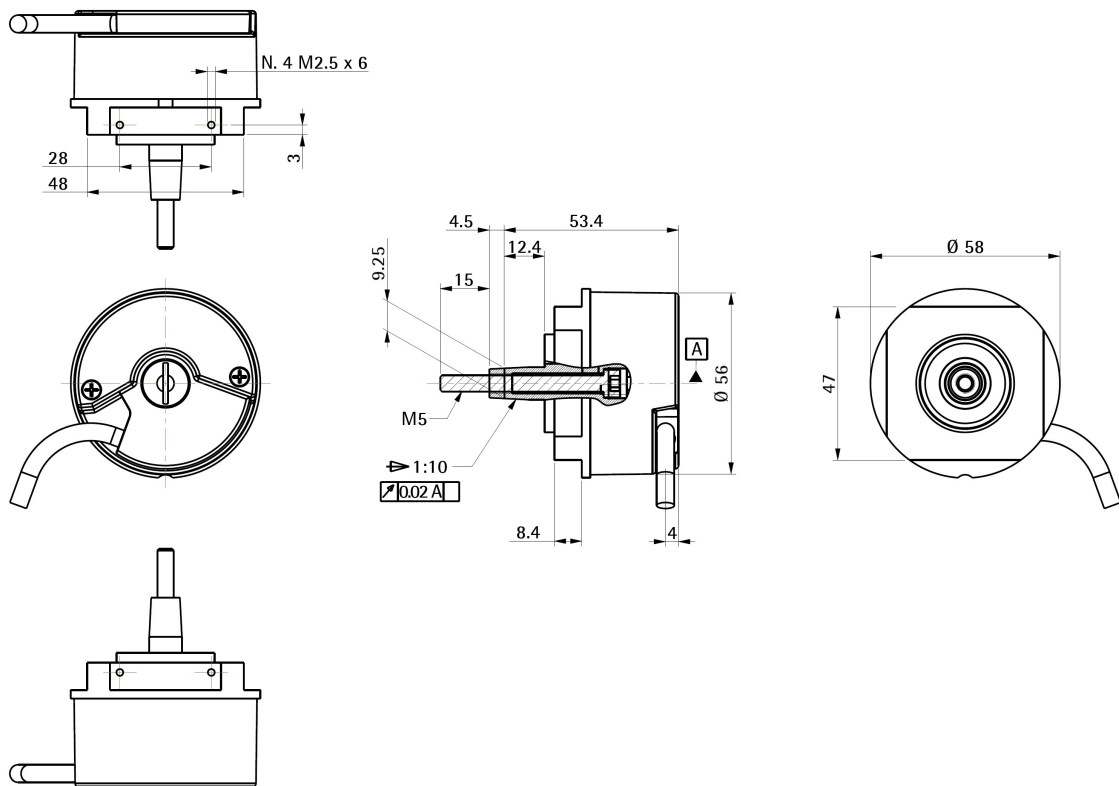

Figure 7 - CB62 encumbrance sizes (A order code)

3.4 CB62 encumbrance sizes (B order code)

(values are expressed in mm)

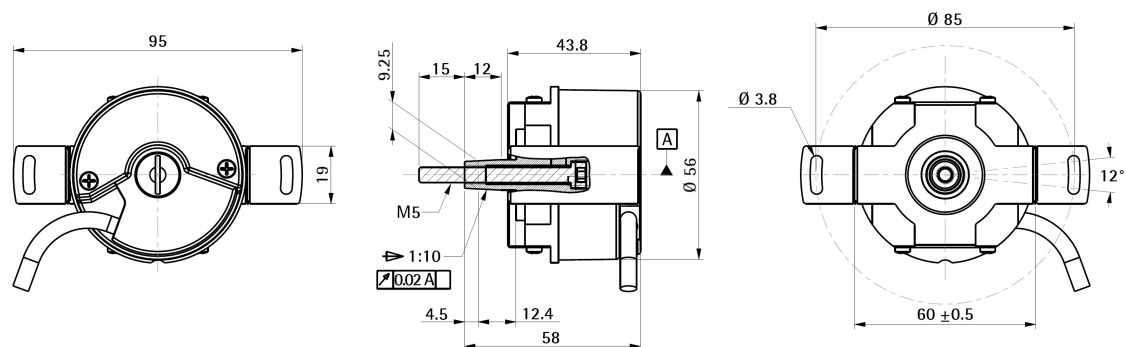

Figure 8 - CB62 encumbrance sizes (B order code)

3.5 CB62 encumbrance sizes (D order code)

(values are expressed in mm)

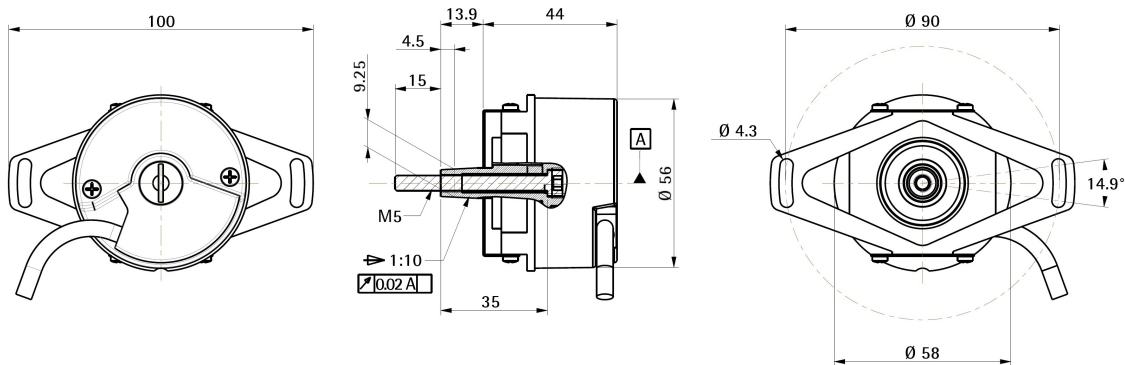

Figure 9 - CB62 encumbrance sizes (D order code)

3.6 CB62 encumbrance sizes (E order code)

(values are expressed in mm)

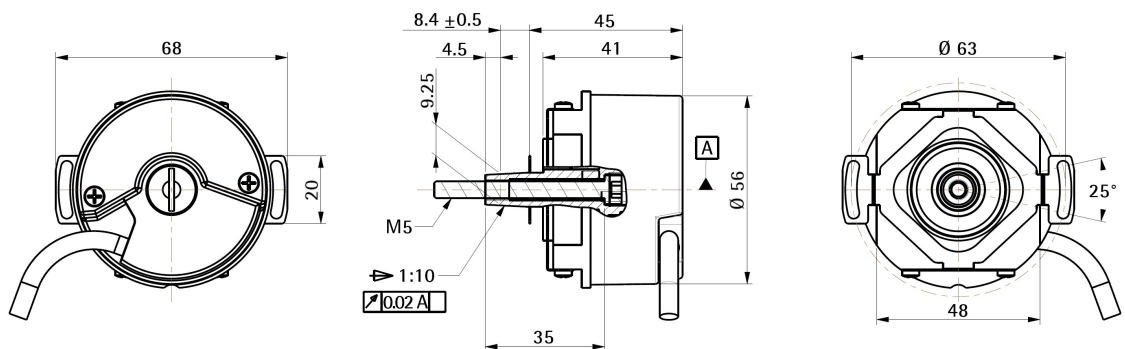

Figure 10 - CB62 encumbrance sizes (E order code)

3.6.1 Mounting the CB62 encoder (A, B, D and E order codes)

For correct installation the motor shaft must be fitted with an M5-threaded bore (see Figures above).

To install the encoder please follow carefully the next steps:

- remove the PG cap 1 from the back of the encoder;

- fit the encoder into the rotor shaft **2** and fix it using the provided M5 x 50 UNI 5931 screw **3**; the recommended tightening torque is **5 Nm**;
- replace the PG cap **1** properly and tighten it;
- B, D and E order codes only: fasten the fixing plate **4** to the motor frame using two appropriate screws **5**: M3 x 5 min. for B and E order codes, recommended tightening torque = **1.2 Nm**; M4 x 5 min. for D order code, recommended tightening torque = **2.8 Nm**.

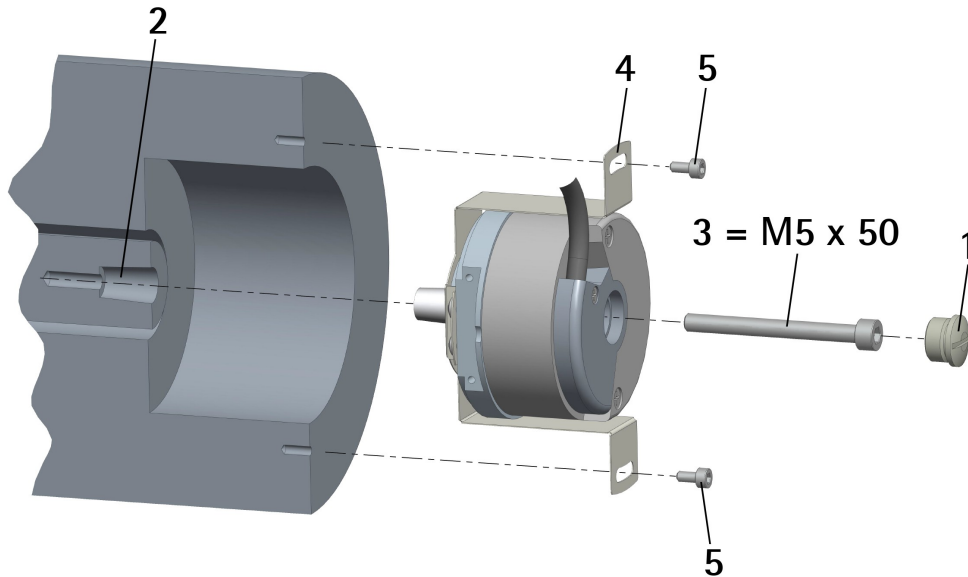

Figure 11 - Example with B type fixing plate

3.6.2 Dismounting the CB62 encoder (A, B, D and E order codes)

To dismount the encoder please follow carefully the steps described hereinafter:

- B, D and E order codes only: unscrew the fixing plate **4** from the motor frame;
- remove the PG cap **1** from the back of the encoder;
- hold the rotor shaft **2** and screw off the M5 screw **3** which fixes the encoder shaft to the rotor shaft **2**.



WARNING: do not force the encoder manually to pull it out!

- ensure that the rotor shaft **2** does not move and carefully tighten an M6 screw instead of the M5 screw in the encoder shaft: tightening the M6 screw will cause the encoder shaft to be drawn out slowly. To prevent the thread of the rotor shaft **2** from being damaged we suggest tightening an M5 grub screw before screwing in the M6 screw.

4 - Electrical connections



WARNING

Power supply must be turned off before performing any electrical connection! If wires of unused signals come in contact, irreparable damage could be caused to the device. Thus they must be cut at different lengths and insulated singularly.

Function	14-pin connector	TF12 cable
C *	1	Violet
A	3	Red
/D *	4	Pink
0Vdc	5	White_Green
/B	6	Brown
0	7	White
/0	8	Blue
B	9	Green
D *	11	Grey
/A	12	Black
+5Vdc \pm 5%	13	Brown_Green
/C *	14	Yellow
not connected	2, 10	-
Shield	Shield	Shield

* C / D signals of the absolute track are provided with option /1 only, see the order code

A, B signals: **Incremental** sine/cosine signals, 2,048 pulses at each complete turn of the encoder shaft.

C, D signals: **Absolute** sine/cosine track, 1 sinusoidal period at each complete turn of the encoder shaft.



WARNING

C / D signals of the absolute track are provided with option /1 only, see the order code

0 signal: **Index "Z-track"**, 1 pulse at each complete turn of the encoder shaft.

For complete information about the signals please refer to the "5 - Output signals" section on page 18.

4.1 98414-G05-14-LF 14-pin connector

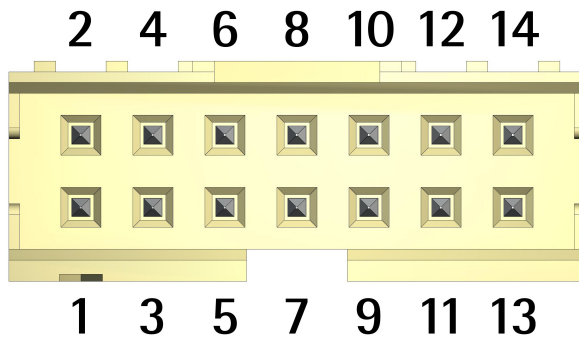

14-pin male connector

Female mating connector: **SQW-107-01-F-D-VS**

4.2 EC-ASB/CB62-xx connection cable

The encoder can be supplied with a connection cable order code **EC-ASB/CB62-xx** where xx is the length of the cable. Refer to the order code for the available cable lengths. The connection cable must be ordered separately.

4.3 TF12 connection cable specifications

Model	: LIKA TF12 encoder cable
Cross section	: 6 x 2 x 28AWG
Jacket	: Special flame retardant PVC compound, RZ-TM2 quality
Shield	: Tinned copper braid, coverage > 80% with tinned copper drain wire
Outer diameter	: 5.4 mm \pm 0.1 mm (0.213" \pm 0.004")
Min. bending radius	: outer diameter x 10
Work temperature	: -15°C +80°C (+5°F +176°F)
Conductor resistance	: < 242.02 Ω /Km (+20°C / -4°F) (UL 758 table 5.2.1)

The total length of the cable that connects the encoder and the receiving device should not exceed the values stated in the "Cable lengths" section of the rotary encoders' catalogue or indicated in this manual; they are specific for each type of output circuit. If you need to reach greater distances please contact Lika Electronic Technical Dept.

4.4 Cable shield connection to ground

To connect the cable shield we suggest gathering the shielding wires together and fixing them by means of a hexagonal metal gland crimped 25 mm / 0.984" away from the connector. Be sure that the gland is in tight contact with the encoder's enclosure. Prevent the shielding wires from coming in contact with the internal electronics.

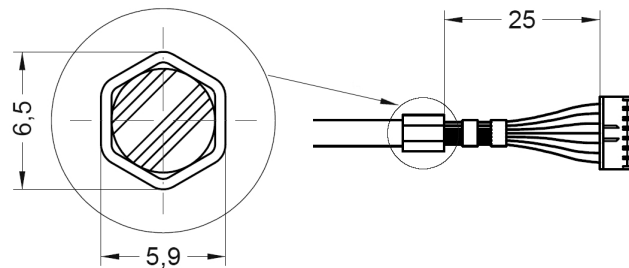

5 - Output signals

The frequency of the output signals is proportional to the shaft rotational speed.

As "Resolution (PPR)" is $2048/x$ (see the order code), then the encoder provides 2,048 **A** and **B** sinusoidal pulses + **Z** track single pulse at each revolution.

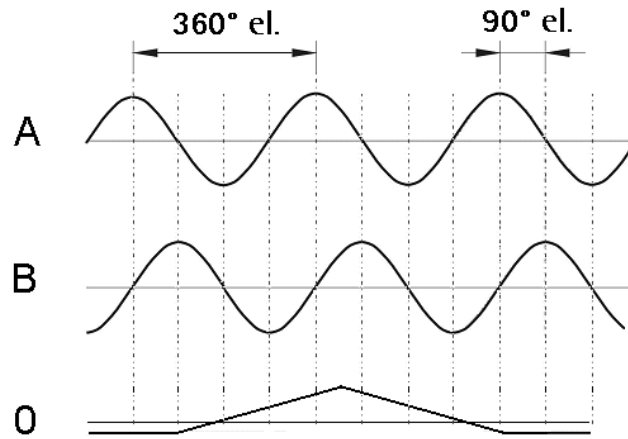

The encoder provides **C** and **D** absolute sinusoidal signals at each turn (absolute track) only if "Resolution (PPR)" is $2048/1$ (see the order code).

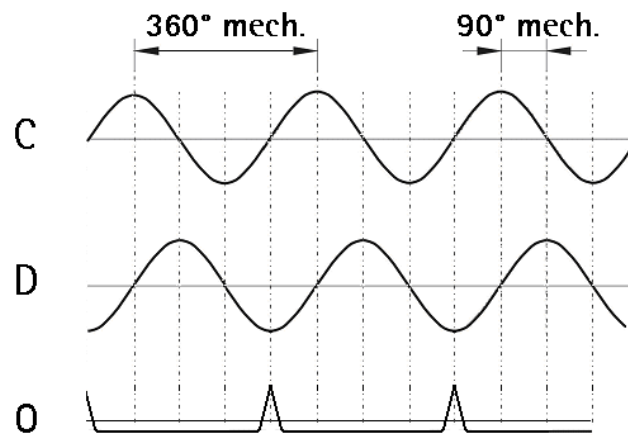

5.1 Output signals level

The voltage level refers to the differential value between normal and inverted signal (differential).

Recommended input circuit

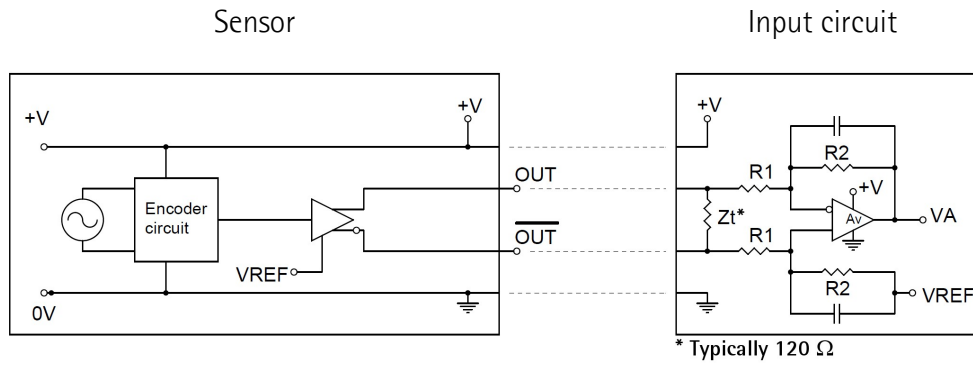

$$V_{REF} = 2.5V \pm 0.5V \quad V_A = 1V_{pp} * A_v \quad A_v = R2 / R1$$

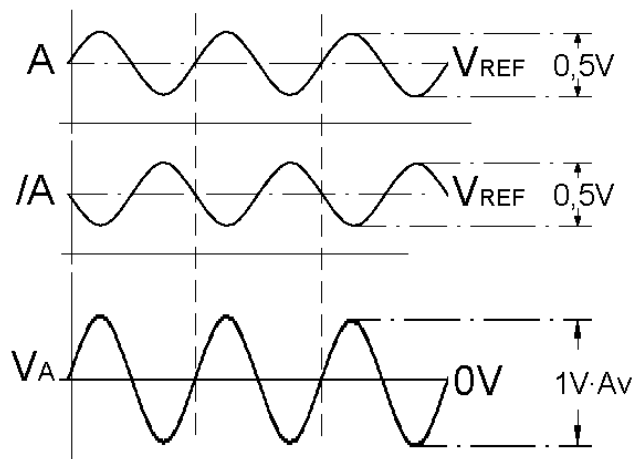

Document release	Release date	Description	HW	SW	Interface
1.0	06.11.2006	First issue	-	-	-
...
1.14	21.09.2016	14-pin connector information added	-	-	-
1.15	27.10.2017	CB62 model information added, CB61 model information removed	-	-	-
1.16	18.12.2019	New connection cable	-	-	-
1.17	30.11.2020	CB60 model information removed, information about new mounting options of CB62 added (order codes A, B, D, E)	-	-	-



This device is to be supplied by a Class 2 Circuit or Low-Voltage Limited Energy or Energy Source not exceeding 30 Vdc. Refer to the order code for supply voltage rate.

Ce dispositif doit être alimenté par un circuit de Classe 2 ou à très basse tension ou bien en appliquant une tension maxi de 30Vcc. Voir le code de commande pour la tension d'alimentation.



Dispose separately

lika

Lika Electronic

Via S. Lorenzo, 25 • 36010 Carrè (VI) • Italy

Tel. +39 0445 806600

Fax +39 0445 806699



info@lika.biz • www.lika.biz